

2 PIECES BALL VALVE PN63 BLUE HANDLE

ISO 9001 : 2008

TÜVRheinland®
PED/97/23/CE

Size : DN 1/4" to 4"
Ends : Threaded BSP
Min Temperature : - 20°C
Max Temperature : + 180°C
Max Pressure : 63 Bars (up to DN3/4")
Specifications : Anti blow-out stem
Locking device
Full bore

Materials : Stainless steel ASTM A351 CF8M

2 PIECES BALL VALVE PN63 BLUE HANDLE

SPECIFICATIONS :

- Full bore
- Anti blow-out stem
- PTFE packing
- Locking device
- Solid ball
- 2 pieces type

USE :

- Chemical and pharmaceutical industries, petrochemical industries, hydraulic installation, compressed air
- Min and max Temperature Ts : -20°C to + 180°C
- Max Pressure Ps : 63 bars up to DN3/4", 50 bars from 1" to 1"1/4, 40 bars from 1"1/2 to 2" , 25 bars from 2"1/2 to 3" , 16 bars for DN4" (see graph)

PRESSURE / TEMPERATURE GRAPH (STEAM EXCLUDED) :

PRESSURE (Bar)

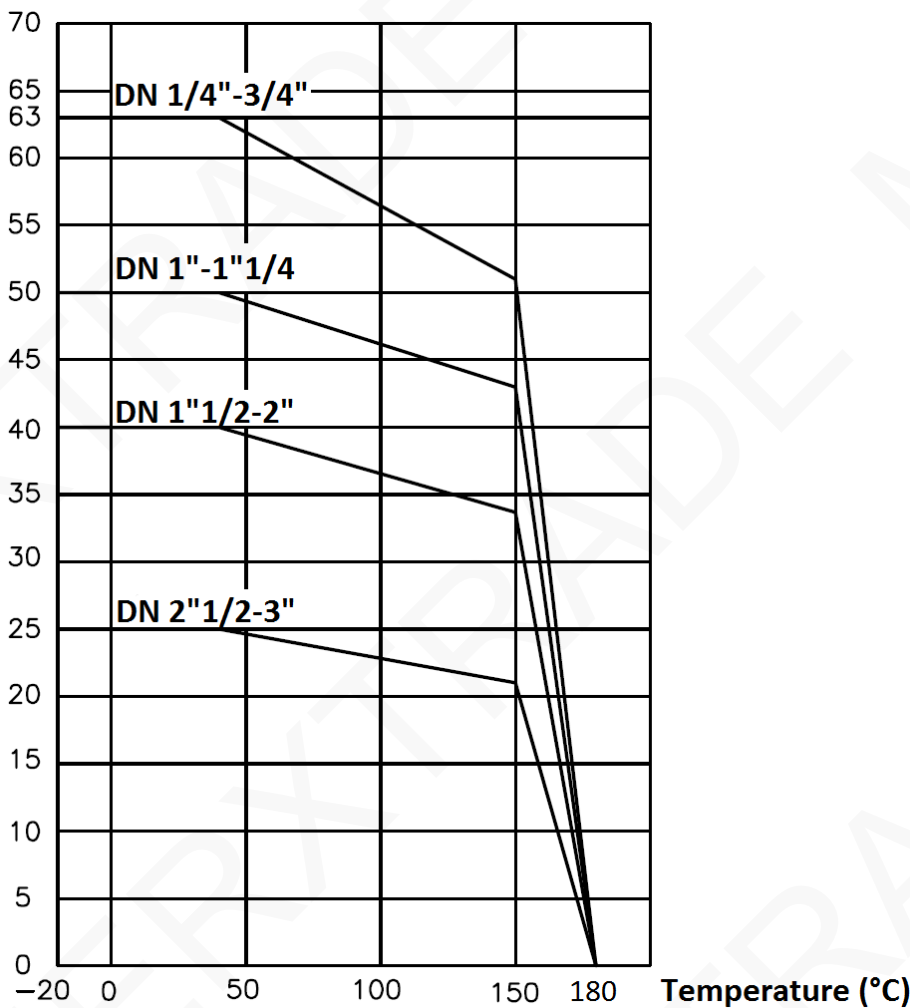

2 PIECES BALL VALVE PN63 BLUE HANDLE

RANGE :



- Ball valve female / female threaded BSP Stainless steel blue handle Ref. 715 from DN 1/4" to DN 4"
- Gaine de poignée rouge Ref. 9830370 à 9830374 du DN 1/4" au DN 3"

MATERIALS :

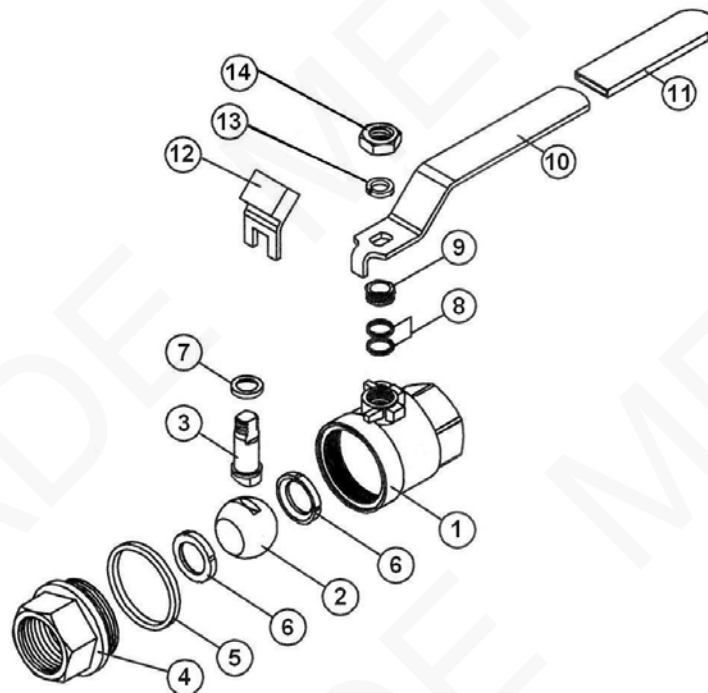

Item	Designation	Materials
1	Body	ASTM A351 CF8M
2	Ball	ASTM A351 CF8M
3	Stem	SS 316
4	Ends	ASTM A351 CF8M
5	Body seal	PTFE
6	Seat	PTFE filled with 3% glass fiber
7	Stem gasket	PTFE
8	Packing	PTFE
9	Packing nut	SS 304
10	Handle	SS 304
11	Handle cover	Plastic
12	Locking device	SS 304
13	Handle washer	SS 304
14	Handle nut	SS 304

2 PIECES BALL VALVE PN63 BLUE HANDLE

SIZE (in mm) :

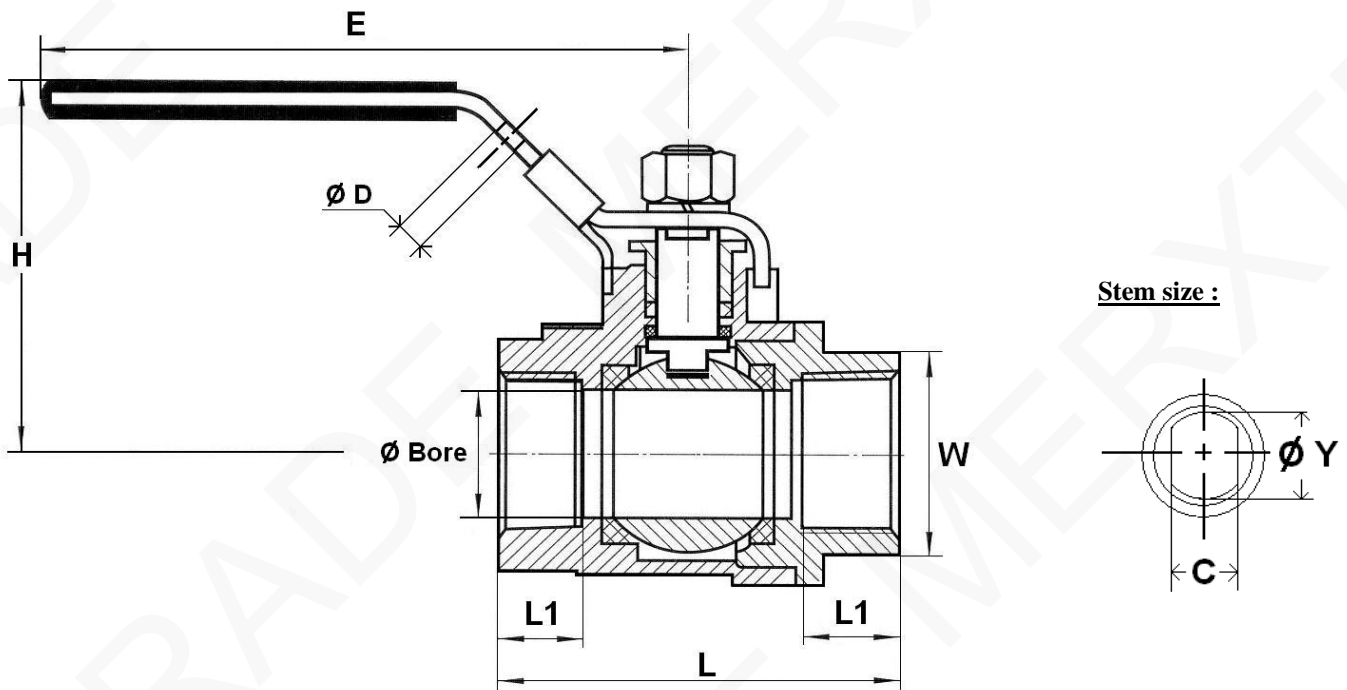

DN	1/4"	3/8"	1/2"	3/4"	1"	1"1/4"	1"1/2"	2"	2"1/2"	3"	4"
Ø Bore	11.6	11.6	15	20	25	32	38	50	65	76	94
L	46.8	48.5	58	65.7	77	90	98	121	145	166	214
Ø D	7.6	7.6	7.6	7.6	7.6	7.6	7.6	7.6	7.6	7.6	7.6
E	105	105	105	128	128	158	158	194	248	248	330
H	44	44	48	61	62	79	86	90	118	126	176
L1	10.5	10.5	13	13.2	15.2	18	18.3	22.5	25.5	28.4	36
W on flat	17	20.8	25.5	31	38.5	48	54	67	83.5	98	128
C	5	5	5	5.8	5.8	7	7	8	12	12	14
Ø Y	8	8	8	8	8	10	10	10	16	16	24
Weight (in Kg)	0.18	0.19	0.26	0.40	0.59	1	1.32	2.46	4.83	7.45	16.5

2 PIECES BALL VALVE PN63 BLUE HANDLE

TORQUE VALUES (in Nm without safety coefficient) :

DN	1/4"	3/8"	1/2"	3/4"	1"	1 1/4"	1 1/2"	2"	2 1/2"	3"	4"
Torque (Nm)	2.7	2.7	3	4	5	6	8	10	40	60	100

STANDARDS :

- Fabrication according to ISO 9001 : 2008
- DIRECTIVE 97/23/CE : CE N° 0035
Risk Category II Module D1
- Pressure Tests according to EN 12266-1, Rate A
- Threaded BSP cylindrical ends according to ISO 228-1

ADVICE : Our opinion and our advice are not guaranteed and MXT shall not be liable for the consequences of damages. The customer must check the right choice of the products with the real service conditions.

INSTALLATION AND MAINTENANCE

BEFORE INSTALLATION :

Pipe-line must be cleaned and free from residual of weldings, rubbish, shaving and every kind of extraneous materials. Pipe-line must be perfectly aligned and their support properly dimensioned so that there's no external constraint.

Please use the right product according to the services conditions to seal the valve.
Use the right bolt tightening so that the ends won't be damaged.

CLEANING AND TESTS

Keep closed the valves during the cleaning operation so that there's no impurities between the ball and the body.

Tests under pressure must be done with a cleaned pipe-line.

Open partially the valve for tests. Pressure test do not exceed the valve specifications according to EN 12266-1.

MAINTENANCE

It's recommended to operate the valve twice (open and close) 1 to 2 times per year.

When intervention on the valve, be sure there's no pressure in the pipe-line, there's no fluid in it, and that it is isolated. The temperature must be low enough to operate without risks.
If there's a corrosive fluid, inert installation before intervention.

When the valve is under pressure :

If there's a leakage at the packing, tighten it slightly so that the leakage disappears.